

AZ16E - Battery operated Absolute Linear Encoder Unit

- Resolution 0.1 mm
- Distances up to 8 meters possible
- External magnetic sensor (plug able)
- Unique offset definition (no further referencing necessary)
- Permanent retention of all data and settings
- Reserve energy up to 3 years
- AUTO-POWER-OFF function with adjustable „switch on“ time
- Switch over for absolute / incremental mode
- Millimeters or Inches operation
- Fraction views in the Inch mode possible
- User friendly menu levels
- Keys can be enabled or disabled individually
- Adjustable reference value and 3 tool offsets
- Symbols individually selectable (mm/inches/arrows etc.)

Applications: Roller tables, slide- and gauge systems, disc saws, manual adjustment units etc. or machines without an available power supply.

The new linear „Absolute“ encoder and indicator unit AZ16 is based on the proven magnetic measuring principle. According to its battery supply, no wirings are necessary and the systems is able to operate as a complete stand alone unit. The max. possible measuring distance amounts to 8 meters. By using the AUTO-POWER-OFF mode the max. service life span of the battery amounts up to 3 years.

The external magnetic sensor is connected fix to the indicator by a drug chain suitable cable.

Characteristics of the AZ16E (external Sensor):

The system consists of

- extensive programmable Display unit
- external Magnetic Sensor, max. cable length 20 meters
- absolute coded Magnetic Tape, max. 8 meters

The sensor will be moved contactless over the magnetic tape. It is resistant against abrasion, dust, dirt and water (protection class IP 67). The user must provide and guarantee for a suitable mechanical guiding system, to guide the sensor and keep it along the whole movement in the correct distance (0... 1.5 mm) to the magnetic tape. The sensor must be installed coplanar to the tape.



AZ16E application example: manual gauge



AZ16I: This version is with integrated sensor and with a complete Guide rail (incl. magnetic tape) is also available



Battery change without any tool



Easiest panel installation



AZ16E rear: with battery case and plug connector

Dimensions of the magnet sensor

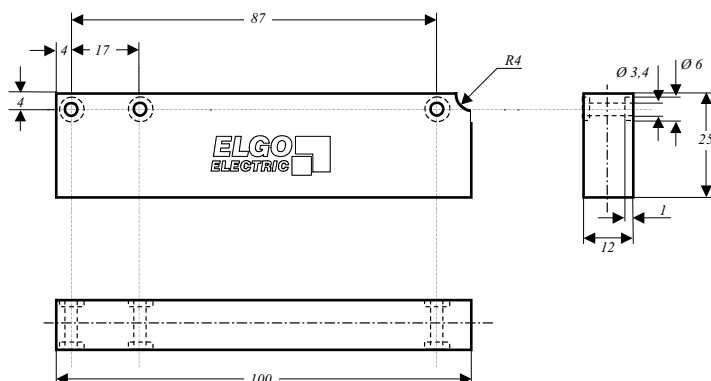

AZ16E - Battery operated Absolute Linear Encoder Unit

Type designation

AZ16E	000-	1-	03.0-	1
--------------	-------------	-----------	--------------	----------

Type

AZ16E : Indicator with external sensor
 AZ16I : Indicator with internal sensor + guidance

SN- Number:

000 = Standard
 001 = First special version

Power supply:

1 = 1 x internal battery size C (only AZ16E)
 2 = 2 x internal batteries size AA (only AZ16I)
 3 = external battery case (1,5V) (only AZ16I)

Sensor cable length

Please indicate desired length in XX,X m (max. 20,0 m) (only AZ16E)

Kabeloption:

0 = fixed cable connection (only AZ16E)
 1 = (Standard) connection via RJ45 plug connector (only AZ16E)

Technical specifications AZ16E

(battery powered absolute encoder and indicator unit)

Power supply	: 1.5 V battery (size C)
Battery life span	: 1... 3 years (depend from adjusted switch on time)
Distance sensor/tape	: max. 1.5 mm
Resolution of sensor	: 0.1 mm
Measurement units	: mm or INCH
max. Measuring distance	: 8 m
max. length of sensor cable	: 20.0 m
Principle of measurement	: Magnetic, absolute
Kind of measurement	: Linear, no rotative tasks possible
LCD-Display	: 6 digits, height 8 mm, + sign + battery condition
Keypad	: membrane keypad
Operation temperature	: + 5... + 50° C
Stock temperature	: 0... 70° C
Humidity	: not condensing, max. 80 %
Altitude	: max. 2000 m above sea level
Protection class (indicator)	: IP 43 (installed state)
Outer dimension (indicator)	: W x H = 96 x 72 mm
Panel cut out	: W x H = 93 x 67 mm
Depth AZ16 E incl. connector	: (install depth) 47 mm (whole depth) 53 mm
Protection class ext. sensor	: IP 67
Dimensions ext. sensor	: see drawing on left

Magnetic tape AB20-40-10-1-R-11

Code	: Absolute, single track
Extension coefficient	: $\alpha = 16 \times 10^{-6} \text{ K}^{-1}$
Linear extension	: $\Delta L = L \times \alpha \times \Delta \vartheta$ (L= measuring length in meters)
Dimensions (W x H)	: 10 mm x ca. 1.8 mm
min. bending radius	: 150 mm
Operation temperature	: 0... + 50° C
Protection class	: IP 67



ELGO
ELECTRIC
Measure / Control / Position

ELGO
ELECTRIC



AZ16E

**Battery operated
ABSOLUTE Linear Encoder Unit**