

EMIX23

Magnetic incremental high μm resolution Linear Encoder

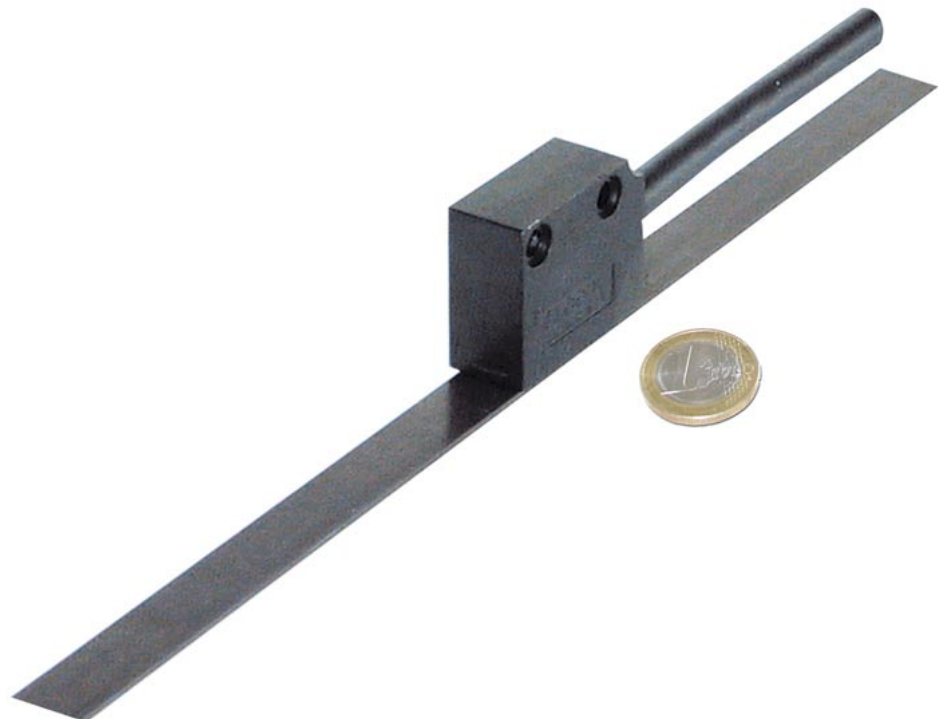

- 1 μm sensor technology in high resolution
- predestined for feedback and control applications
- wear free measuring principle
- contactless scanning of position
- allowed distance sensor/tape: up to 0.8 mm
- insensitive against dust, dirt and water
- differential 5 V-TTL or 10... 30 V- HTL output logic
- additionally periodic index-pulse output
- Resolution = 0,001 mm
(at four edge triggering)
- Repeating accuracy +/- 0,001 mm
- Sensor with integrated translator
- speed-proportional square wave outputs

Technical specifications

SENSOR electrical data	Type: EMIX23
Measuring principle	Incremental
Signal output	Speed proportional
Resolution at 4 edge triggering	0.001 mm
Repeat accuracy	+/- 0.001 mm
Accuracy of the system in μm at 20 ° C	+/- 25 + 20 x L (L = measuring length in meters)
Max. permitted distance to the tape	0.8 mm
Power supply	5 VDC or 10... 30 VDC
Tolerance of power supply	5 VDC: +/- 2.5 %, remaining ripple < 50 mV 10... 30 VDC: +/- 10 %, remaining ripple < 5 %
Consumption	5 VDC: max. 200 mA 10... 30 VDC: max. 150 mA
Translator circuit intern/extern	intern
Output levels	5 VDC - TTL Line Driver or 10... 30 VDC - HTL
Output channels	A, A', B, B', Z, Z'
Output characteristics	Push/pull, durable short circuit proof
Max. output frequency per channel	TTL: 100 KHz at 0.4 m/s resp. 500 KHz at 2.0 m/s HTL: 100 KHz at 0.4 m/s resp. 500 KHz at 2.0 m/s, at optimal evaluation!
Output current per channel	20 mA
Max. operating speed	2.0 m/s
Index pulses	Periodic output of channels Z and Z'
Maximum length of wire	5 VDC / 5 V-TTL = 10 m 10-30 VDC / 10-30 V-HTL = 30 m 10-30 VDC / 5 V-TTL = 50 m
Min. bend radius of sensor cable	60 mm' s
Operation temperature	0... + 50 ° C
Stock temperature	-20... + 70 ° C
Humidity	95 %, not condensing
Necessary magnetic tape	MB20.20
Angular tolerances (assembly)	See drawing page 5 chapter 6.1
SENSOR HEAD mechanical data	
Housing	Zinc die cast
Protection class	IP67
Dimensions L x W x H	30 mm x 12.5 mm x 25 mm
Mounting position	Horizontal or vertical (Option L)
Mechanical guidance	None
MAGNETIC TAPE	Type: MB20.20
Pole distance	2 mm' s
Extension coefficient (in meters)	$\alpha = 16 \times 10^{-6} \text{ K}^{-1}$
Linear extension	$\Delta L = L \times \alpha \times \Delta\theta$
Dimensions W x H	10 mm x ca. 1.8 mm
Min. bend radius	150 mm' s
Protection class	IP67

Dimensions

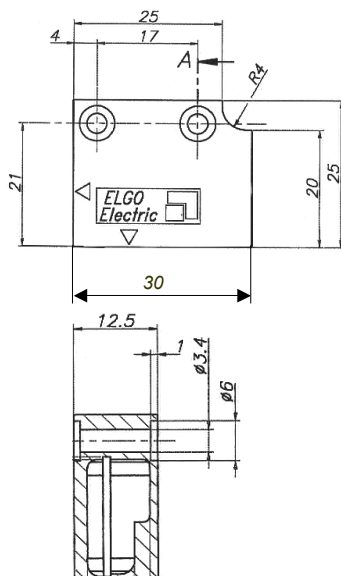

Type designation

EMIX23 - XXX - XX.X - X - XX - XXX

Series/type

SN-Nummer

000 = standard
001 = first customer specified version
002... etc.

Signal wire length in XX.X m

Resolution (at EMIX23 always index 7)
7 = 0.001 mm (at 4 x edge triggering)
Other resolutions are available on request.

Power supply / output level

00 = 10-30 VDC / 10-30 V-HTL
01 = 10-30 VDC / 5 V-TTL line driver
11 = 5VDC / 5V-TTL line driver

Options

D1 = 9 pin D-SUB connector (pin assignment as ELGO-standard)
L = Vertical sensor position (PCB and sensor installation)

Accessories:

MB20.20 - XX.X

ELGO magnetic tape 2 mm pole division

Length (in m)